



SOT-223



Pin Definition:

1. Base
2. Collector
3. Emitter

PRODUCT SUMMARY

BV_{CBO}	-500V
BV_{CEO}	-500V
I_C	-150mA
$V_{CE(SAT)}$	-0.5V @ $I_C / I_B = -50mA / -10mA$

Features

- Low Saturation Voltages
- Excellent gain characteristics specified up to -50mA

Structure

- Epitaxial Planar Type
- PNP Silicon Transistor

Ordering Information

Part No.	Package	Packing
TSA874CW RPG	SOT-223	2.5Kpcs / 13" Reel

Note: "G" denotes for Halogen Free

Absolute Maximum Rating (Ta = 25°C unless otherwise noted)

Parameter	Symbol	Limit	Unit
Collector-Base Voltage	V_{CBO}	-500	V
Collector-Emitter Voltage	V_{CEO}	-500	V
Emitter-Base Voltage	V_{EBO}	-5	V
Collector Current	DC	-150	mA
	Pulse	-500	
Total Power Dissipation	P_{tot}	1	W
Operating Junction Temperature	T_J	+150	°C
Operating Junction and Storage Temperature Range	T_{STG}	- 55 to +150	°C

Electrical Specifications (Ta = 25°C unless otherwise noted)

Parameter	Conditions	Symbol	Min	Typ	Max	Unit
Collector-Base Breakdown Voltage	$I_C = -100\mu A, I_E = 0$	BV_{CBO}	-500	--	--	V
Collector-Emitter Breakdown Voltage	$I_C = -10mA, I_B = 0$	BV_{CEO}	-500	--	--	V
Emitter-Base Breakdown Voltage	$I_E = -100\mu A, I_C = 0$	BV_{EBO}	-5	--	--	V
Collector Cutoff Current	$V_{CB} = -120V, I_E = 0$	I_{CBO}	--	--	-100	nA
Emitter Cutoff Current	$V_{EB} = -6V, I_C = 0$	I_{EBO}	--	--	-100	nA
Collector-Emitter Saturation Voltage	$I_C = -20mA, I_B = -2mA$	$V_{CE(SAT)1}$	--	--	-0.2	V
	$I_C = -50mA, I_B = -10mA$	$V_{CE(SAT)2}$	--	--	-0.5	
Base-Emitter Saturation Voltage	$I_C = -50mA, I_B = -10mA$	$V_{BE(SAT)}$	--	--	-0.9	V
Base-Emitter on Voltage	$V_{CE} = -10V, I_C = -50mA$	$V_{BE(ON)}$	--	--	-0.9	V
DC Current Transfer Ratio	$V_{CE} = -10V, I_C = -1mA$	h_{FE1}	150	--	300	
	$V_{CE} = -10V, I_C = -50mA$	h_{FE2}	80	--	300	
	$V_{CE} = -10V, I_C = -100mA$	h_{FE3}	--	15	--	
Transition Frequency	$V_{CE} = 10V, I_C = -100mA$	f_T	--	50	--	MHz
Output Capacitance	$V_{CB} = 20V, f = 1MHz$	C_{ob}	--	--	8	pF
Turn On Time	$V_{CE} = -100V, I_C = -50mA$	T_{on}	--	110	--	nS
Turn Off Time	$I_{B1} = -5mA, I_{B2} = -10mA$	T_{off}	--	1500	--	nS

Electrical Characteristics Curve ($T_a = 25^\circ\text{C}$, unless otherwise noted)

Figure 1. Static Characteristics

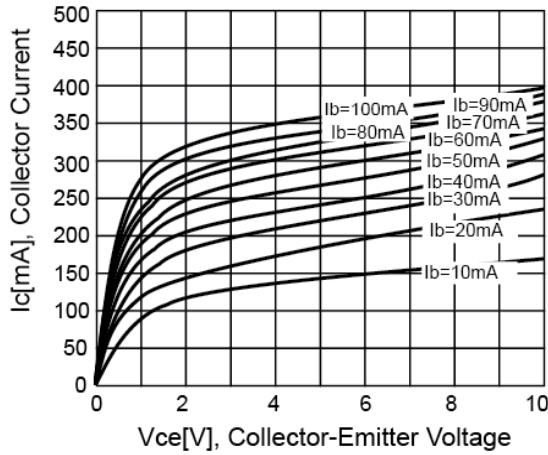

Figure 2. DC Current Gain

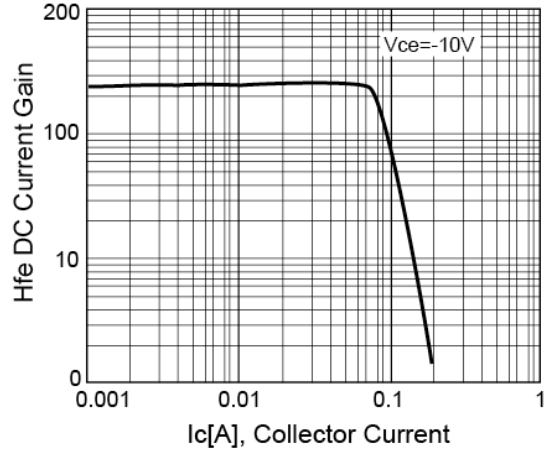

Figure 3. VCE(SAT) v.s. VBE(SAT)

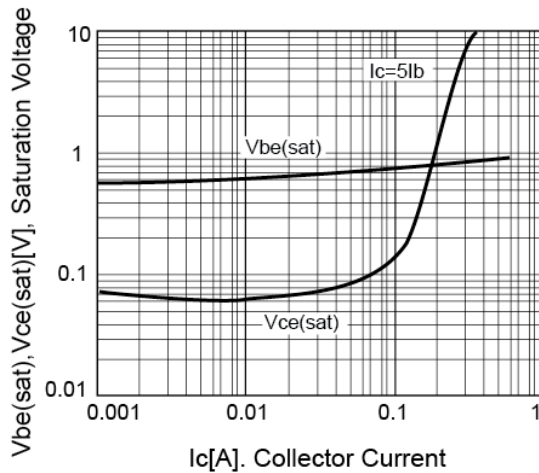

Figure 4. Power Derating

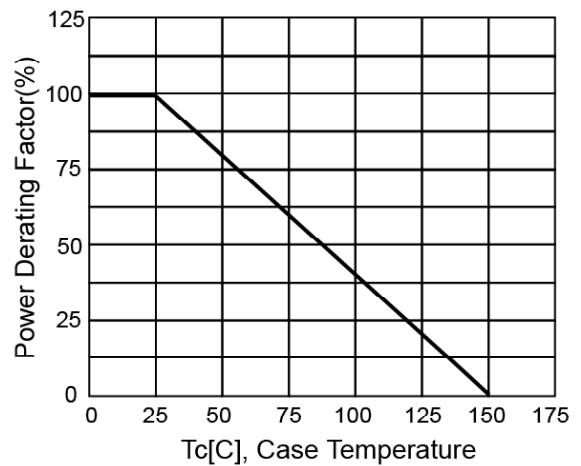
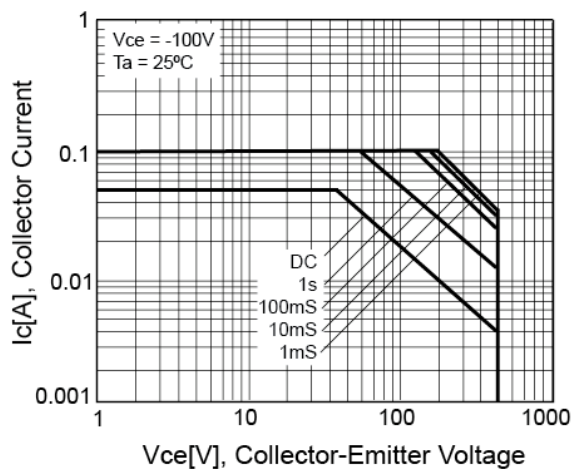
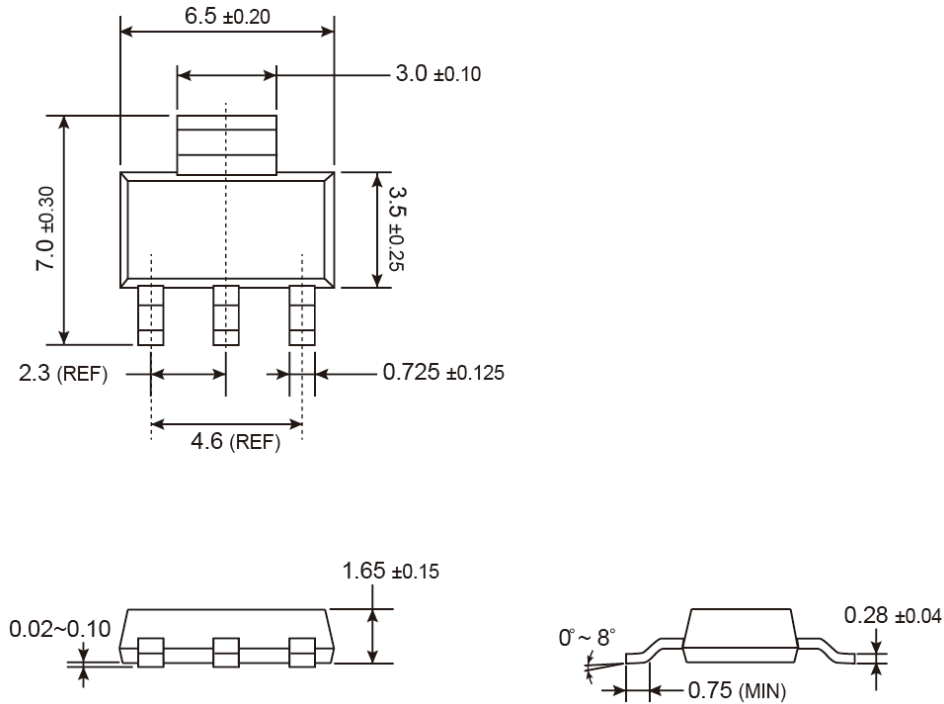

Figure 5. Safety Operation Area



SOT-223 Mechanical Drawing



Unit: Millimeters

Marking Diagram

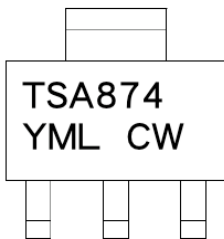

- Y** = Year Code
- M** = Month Code for Halogen Free Product
 - O** =Jan **P** =Feb **Q** =Mar **R** =Apr
 - S** =May **T** =Jun **U** =Jul **V** =Aug
 - W** =Sep **X** =Oct **Y** =Nov **Z** =Dec
- L** = Lot Code